

SIDE VIEW

PLAN VIEW

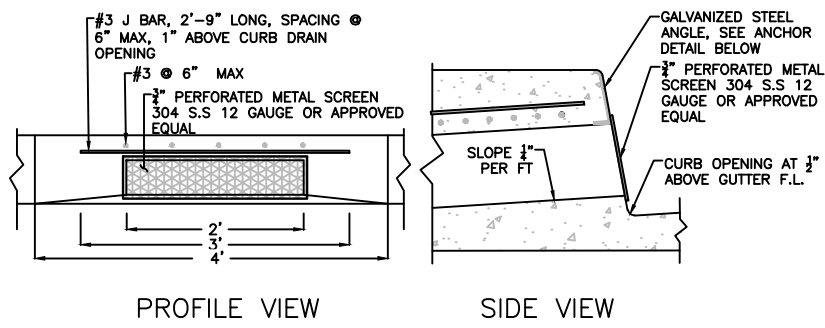

CURB INLET DETAIL

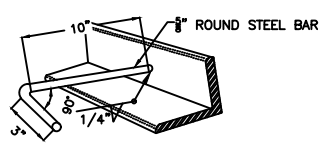

DETAIL OF ANCHOR

(SEE NOTES 12 & 13)

NOTES:

1. TREE TYPE SHALL BE APPROVED BY CITY ENGINEER.
2. TREE SHALL BE IN 24" X 24" BOX AND HAVE MINIMUM DIMENSIONS OF 8 FT HIGH, 3 FT WIDE AT THE HEAD AND A TRUNK OF 2 INCHES.
3. TREE SPACING 50' OR PER CITY ENGINEERS DIRECTION.
4. PLANT 25' MIN. FROM B.C.R. AT INTERSECTIONS.
5. PLANT 25' MIN. FROM EDGE OF DRIVE APPROACH.
6. PLANT 10' MIN. FROM UTILITY AND SEWER LINES.
7. PLANT 21' MIN. FROM STREET LIGHT STANDARDS.
8. PLANT 15' MIN. FROM POWER POLES.
9. PLANT 10' MIN. FROM FIRE. HYDRANTS.
10. ONE YEAR WARRANTY FOR LOSS OR DAMAGE REQUIRED.
11. FLOOR OF BOX TO BE TROWELED SMOOTH.
12. THE HEADED STEEL STUD 5/8" X 6 3/8" WITH HEAD D=1" ATTACHED BY A FULL PENETRATION BUTT WELD MAY BE USED AS AN ALTERNATE ANCHOR.
13. THE 3" LEG OF THE INTERIOR ANCHORS SHALL BE PARALLEL TO THE TOP OF THE SIDEWALK.
14. LOCAL DEPRESSION SHALL BE 2 1/2" FOR AN EXISTING 6" CF OR 1/2" FOR AN EXISTING 8" CF.

REVISIONS		
DATE	DESCRIPTION	INITIALS
9/17/18	REDESIGNED	MB
11/28/18	UPDATED	MB
2/16/22	UPDATED	AE
05/10/22	UPDATED	MB
6/23/22	UPDATED	MB

**STANDARD TREE
PLANTING**
CITY OF VERNON, PUBLIC WORKS DEPARTMENT
JUNE 2022

STANDARD PLAN
MV 1891
1 OF 2

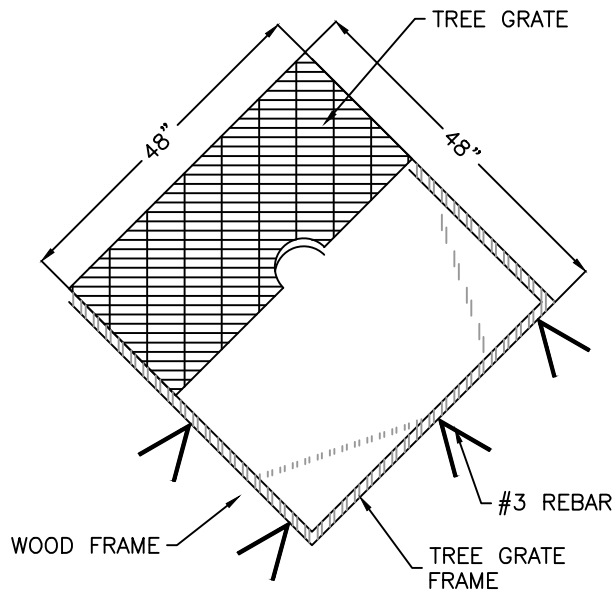

TREE GRATE INSTALLATION DETAIL

INSTALLATION PROCEDURE:

1. PLACE WOOD FRAME WITHIN EXCAVATION.
2. FORM OUTSIDE DIMENSION SHALL BE 45.75" X 45.75"
3. FRAME SHALL BE ASSEMBLED PER MANUFACTURER'S INSTRUCTIONS. COUNTERSUNK FLATHEAD SCREWS MUST BE VANDAL RESISTANT AND SHALL BE TIGHTENED SO THEY ARE FLUSH OR BELOW THE BEARING SURFACE OF THE FRAME.
4. PLACE FRAME ON WOOD FORM AND TREE GRATE WITHIN THE FRAME. SEAT FRAME MUST BE CLEANED PRIOR TO SETTING THE GRATE.
5. GRATES, FRAMES AND FORM SHALL BE WIRED TOGETHER.
6. INSTALL #3 REBAR THROUGH LUGS ON FRAME AND SUPPORT AS REQUIRED.

NOTES:

1. TREE WELL SHALL HAVE THE SAME SLOPE AS SURROUNDING SIDEWALK.
2. TREE GRATE SHALL BE RELIANCE FOUNDRY R-8708 FOR A 48"X48" TREE WELL OR APPROVED EQUAL.
3. OPENINGS IN TREE GRATE SHALL BE ADA COMPLIANT.

REVISIONS		
DATE	DESCRIPTION	INITIALS
9/17/18	REDESIGNED	MB
11/28/18	UPDATED	MB
2/16/22	UPDATED	AE
6/23/22	UPDATED	MB

**STANDARD TREE
PLANTING**
 CITY OF VERNON, PUBLIC WORKS DEPARTMENT
 JUNE 2022

STANDARD PLAN
MV 1891
 2 OF 2